



**HAL**  
open science

## Toward scalability evaluation of multi-model lines

Xavier Delorme, Audrey Cerqueus

► **To cite this version:**

Xavier Delorme, Audrey Cerqueus. Toward scalability evaluation of multi-model lines. IFAC-PapersOnLine, 2022, 10th IFAC Conference on Manufacturing Modelling, Management and Control MIM 2022, 55 (10), p.1663-1668. 10.1016/j.ifacol.2022.09.636 . emse-03853762

**HAL Id: emse-03853762**

**<https://hal-emse.ccsd.cnrs.fr/emse-03853762v1>**

Submitted on 19 Dec 2023

**HAL** is a multi-disciplinary open access archive for the deposit and dissemination of scientific research documents, whether they are published or not. The documents may come from teaching and research institutions in France or abroad, or from public or private research centers.

L'archive ouverte pluridisciplinaire **HAL**, est destinée au dépôt et à la diffusion de documents scientifiques de niveau recherche, publiés ou non, émanant des établissements d'enseignement et de recherche français ou étrangers, des laboratoires publics ou privés.



Distributed under a Creative Commons Attribution - NonCommercial - NoDerivatives 4.0 International License

## Toward scalability evaluation of multi-model lines

Xavier Delorme\* Audrey Cerqueus\*\*

\* *Mines Saint-Etienne, Univ Clermont Auvergne, INP Clermont Auvergne, CNRS, UMR 6158 LIMOS, F-42023 Saint-Etienne, France (e-mail: delorme@emse.fr).*

\*\* *IMT Atlantique, LS2N, UMR CNRS 6004, F-44307 Nantes, France (e-mail: audrey.cerqueus@imt-atlantique.fr)*

**Abstract:** Manufacturing companies are nowadays facing the high volatility of market conditions and the need for increased customization, which lead them to consider Reconfigurable Manufacturing Systems (RMS) as a way to react quickly and efficiently to changes in order to remain competitive. Two important characteristics of such systems are the scalability and the customization. Scalability and customization refer to the ability to change the throughput capacity and to the flexibility to produce various models from the same part family, respectively. However, if both characteristics have been studied in the literature in recent years, they are usually considered independently. In this article, we are proposing a new scalability indicator dedicated to the case of multi-model RMS as well as a procedure to generate a set of configurations. An illustrative example is presented to explain the main differences with the single-model case.

Copyright © 2022 The Authors. This is an open access article under the CC BY-NC-ND license (<https://creativecommons.org/licenses/by-nc-nd/4.0/>)

**Keywords:** Reconfigurable Manufacturing Systems, Scalability, Customization, Multi-model lines, Batch production.

### 1. INTRODUCTION

Today's manufacturing companies have to face a quickly evolving demand, with the customers' desire for customized products. To remain competitive their systems must produce in a cost-effective way but also be able to efficiently reconfigure when the volume of the demand or the specification of the products change. Reconfigurable manufacturing systems (RMS) were introduced by Koren et al. (1998) to answer to these requirements. The typical structure of these systems is centered around a main conveyor, insuring the transport of parts between the serial stages<sup>1</sup>, each are composed of several identical resources (Computer Numerical Control, Reconfigurable Manufacturing Tools, workers, cobots...) joined by a gantry. Works in the literature sometimes denote these systems as parallel-serial lines with crossover (see for example Freiheit et al., 2004).

An important feature of RMS is the ability to produce different models in a family, i.e. the customization. If these models are produced in batches, the system is usually called multi-model in the literature (see e.g. van Zantende Fokkert and de Kok, 1997). Since the models belong to the same family, most of the operations are common and are therefore usually processed at the same stage for each model. However, as the processing time of an operation depends on the model, the takt time of each model can be different. Figure 1 shows the organization of batch production in a multi-model system.

<sup>1</sup> These stages are also called stations in the line balancing literature and both words could be used alternatively. In the following we will stick with stage as in Koren et al. (2018)

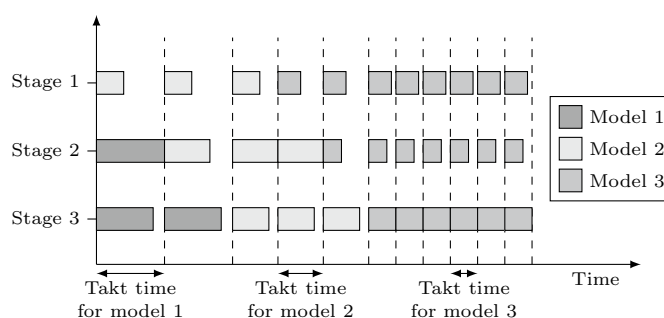

Fig. 1. Example of multi-model production

Two other features of RMS are important to deal with uncertainty: the scalability and the convertibility. The former is the ability to adapt the volume of production, i.e. in a mix model environment the global throughput volume keeping the same product mix. The latter is the ability to change the product mix, i.e. either to change the respective demand level of the different models or to introduce new models. Koren et al. (2017) states that the scalability might be the most important feature of RMS. The two main levers of scalability are the ability to add or remove parallel resources and the possibility to reconfigure the machines. In this study, we focus on the first lever and we propose a new scalability indicator for multi-model RMS.

In this paper, we extend the scalability indicator of Wang et al. (2017) from the single-model RMS to the multi-model RMS. The remainder of the article is organized as follows: Section 2 presents the related literature, Section 3

explains the new scalability indicator, which is illustrated on a didactic example in Section 4, and the paper is concluded by Section 5 with some perspectives.

## 2. LITERATURE REVIEW

With the recent evolution of the customers' needs and desires, interest for RMS has grown in the last decades, as can attest literature reviews, for example Andersen et al. (2015); Bortolini et al. (2018); Yelles-Chaouche et al. (2021).

Multi-model systems are of particular interest in this context to answer customized demand by producing multiple product models on the same system. Dolgui et al. (2021) compared the performance of one multi-model system to multiple dedicated systems and analyzed the parameters impacting the performance (product demand and selling prices, setup and manufacturing times, demand and production cancellations). Hu et al. (2011) presented a literature review on the design and operation of assembly line with multiple models. Regarding the optimization of multi-model system, two main axis which have been particularly studied in the literature are the line balancing and the configuration planning:

- On line balancing, Battaïa and Dolgui (2013) and Sivasankaran and Shahabudeen (2014) presented literature reviews which includes sections dealing with multi-model lines. Thomopoulos (1970) was among the first paper to study the minimization of idle time in a line balancing problem with multiple models produced in batches. Kabir and Tabucanon (1995) considered the multi-model line balancing problem, taking into account several objectives, among which the number of stations, the changeover time, production rate and variety. More recently, Kovalev et al. (2017) proposed an linear programming model and heuristics for the multi-model line balancing minimizing the number of stations and activation cost of the machines and Yelles-Chaouche et al. (2020) aimed to optimize the operation re-assignments from one model to another to minimize the costs for RMS.
- On configuration planning, Dou et al. (2010) used a genetic algorithm to optimize the configuration selection in RMS, with objectives on the number of workstations, the number of paralleling machines and the assigned operation setups. Youssef and El-Maraghy (2008) presented two metaheuristics, taking into account multiple aspects such as the arrangement of machines, the equipment selection, the assignment of operations. Ashraf and Hasan (2018) also considered the configuration selection, by optimizing simultaneously the reconfigurability, the capability and the reliability with a multi-objective approach.

Whereas multi-model lines have gained some attention in the literature on balancing and planning problems, the scalability of RMS has mainly been studied for single-model systems. Son et al. (2001) investigated the link between the balancing of the system and its scalability. In Koren and Shpitalni (2010), the authors studied the impact of the numbers of configurations available and the structure of the RMS. Deif and ElMaraghy (2006, 2007) proposed a dynamic method optimizing each reconfigura-

tion independently and assessed different reconfiguration policies on various scenarios of demand evolution. Wang and Koren (2012) presented a genetic algorithm, simultaneously changing the system configuration and rebalancing the reconfigured system, for successive reconfigurations. They also proposed a first metric assessing the scalability by the smallest possible incremental capacity change. Based on this metric, Delorme et al. (2016) proposed a procedure to generate the set of trade-off configurations and Wang et al. (2017) presented a first evaluation based on the set of possible configurations, taking into account the gap between the minimum and maximum throughput and the average gap between the configurations. Cerqueus and Delorme (2021) proposed a multi-objective evaluation of the scalability considering all the available configurations. All these performance measures are defined for single-model systems.

Finally, some works have considered the possibility to change the system for a new product (i.e. the convertibility of the system), along with the scalability (e.g. Hees et al. (2017) and Hu et al. (2017) for production planning, Napoleone et al. (2019) classifying the main root causes of these two key features and Rösiö et al. (2019) providing a list of key enablers for them). However, very few works have focused on system handling simultaneously several products, with the sole exception of Moghaddam et al. (2020) where the authors propose an Integer Linear Program to minimize the reconfiguration costs of a system composed exclusively of Reconfigurable Manufacturing Tools by changing the modules used to process a given new product-mix. Indeed, this approach only works step by step and does not allow to evaluate the future scalability of the designed system. Overall it seems that the customization and scalability features of RMS have actually been considered independently in research works and Koren et al. (2018) highlighted the need for future research looking at these two issues together.

## 3. A NEW SCALABILITY INDICATOR FOR MULTI-MODEL LINES

Let's consider a set  $F$  of models produced by a RMS composed of  $m$  stages. The product mix is  $\{n_f : f \in F\}$ . The current state of the RMS can be defined by the workload on each stage for each model  $\{W_k^f : k \in 1, \dots, m, f \in F\}$  and by the number of parallel resources assigned to each stage  $\{r_k : k \in 1, \dots, m\}$ . The RMS can thus produce each model  $f$  with a takt time  $T_f = \max_{k \in 1, \dots, m} \{W_k^f / r_k\}$  which means that the time needed to produce the whole product mix is  $D = \sum_{f \in F} n_f \cdot T_f$ <sup>2</sup> and the throughput capacity per unit of time is equal to  $\sum_{f \in F} n_f / D$ .

Usually, the scalability of a RMS can be defined as the incremental capacity which could be obtained for a minimal cost (i.e., one additional resource) (Wang and Koren, 2012).

<sup>2</sup>  $D$  is defined assuming that the setup times between models can be neglected. Indeed, setup times generally depend on batch size and model sequence, both of which are decisions made in the planning phase and therefore are not known in the design phase considered in this paper.

If an additional resource is added to the stage  $k$ , then the new takt time of each model  $T'_f(k)$  is calculated according to (1) and the time needed to produce the whole product mix  $D'(k)$  can be updated (2).

$$T'_f(k) = \max \left\{ \frac{W_k^f}{(r_k + 1)}; \left\{ \frac{W_{k'}^f}{r_{k'}} : k' \in 1, \dots, m, k' \neq k \right\} \right\}, \forall k \in 1, \dots, m \quad (1)$$

$$D'(k) = \sum_{f \in F} n_f \cdot T'_f(k), \forall k \in 1, \dots, m \quad (2)$$

Actually, adding a resource to a stage  $k$  can only reduce the takt time of a model  $f$  if this stage is a bottleneck for this model (i.e.,  $W_k^f/r_k = T_f$ ). Since each model can have a different bottleneck, throughput increase can come from the addition of a resource to various stages. Among them, the one leading to the largest increase determines the maximal capacity increment. Thus, keeping the same product mix, the scalability factor  $\sigma$  can be defined as the ratio between the future throughput capacity and the current one (3).

$$\sigma = \frac{\max_{k \in 1, \dots, m} \left\{ \frac{n_f}{D'(k)} \right\}}{\frac{n_f}{D}} = \frac{D}{\min_{k \in 1, \dots, m} \{D'(k)\}} \quad (3)$$

Based on the scalability indicator  $\sigma$ , we can extend the approach proposed by Delorme et al. (2016) to obtain a set of configurations using the same balancing. Starting from an initial configuration with only one resource for each stage, we can incrementally generate new configurations maximizing the capacity until the maximum number of resources per stage  $r_{max}$  is reached (see Algorithm 1).

#### 4. ILLUSTRATION ON A DIDACTIC EXAMPLE

To illustrate the scalability indicator and the process to derive a set of configurations for a given balancing, we present a small example in this section. Three models of the same family have to be produced by the system. The processing time of the operations to be performed for these three models are given in Table 1. All eight operations are not necessarily needed for each model, this case being indicated by “-” in the table. The product mix is  $\{n_1 = 60, n_2 = 30, n_3 = 10\}$ .

The joint precedence graph, which integrates the precedence relations from each model as described in van Zantede Fokkert and de Kok (1997), is given by Figure 2. We assume that the maximum number of resources per stage is  $r_{max} = 3$ .

Let us consider a balancing  $B_1$  assigning the operations  $\{1, 2, 3\}$  to the first stage,  $\{5\}$  to the second and  $\{4, 6, 7, 8\}$  to the last. The type of resource used on each stage is determined based on the assigned operations, and the workload on each RMS stage is given in Table 2.

Operation	Processing times		
	Model P1	Model P2	Model P3
1	10	-	7
2	1	-	3
3	9	10	-
4	3	-	1
5	8	10	11
6	-	11	5
7	2	1	3
8	14	13	10

Table 1. Processing time of the operations for the three models, “-” indicates that the operation is not required for the model.

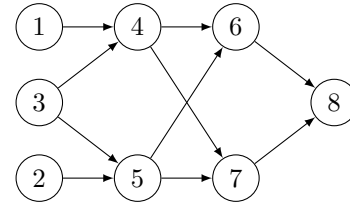

Fig. 2. Precedence graph on the operations of the three products

	Stage 1	Stage 2	Stage 3	Takt time
Model 1	$W_1^1 = 20$	$W_2^1 = 8$	$W_3^1 = 19$	$T_1 = 20$
Model 2	$W_1^2 = 10$	$W_2^2 = 10$	$W_3^2 = 25$	$T_2 = 25$
Model 3	$W_1^3 = 10$	$W_2^3 = 11$	$W_3^3 = 19$	$T_3 = 19$

Table 2. Workloads and takt times resulting from the balancing  $B_1$  for the three models.

The first configuration  $C_a$  generated by Algorithm 1 has one resource on each stage. The time needed to produce the whole product mix is given by (4).

$$D = 60 \times 20 + 30 \times 25 + 10 \times 19 = 2140 \quad (4)$$

In configuration  $C_a$ , the bottleneck stages are the first stage (for P1) and the third stage (for P2 and P3), so adding resources to the second stage would be useless. Thus the algorithm computes  $D'(1)$  and  $D'(3)$  according to (5) and (6), leading respectively to the configurations  $C_b$  (with two resources on Stage 1 and one on Stages 2 and 3) and  $C_c$  (with one resource on Stages 1 and 2 and two on Stage 3). Actually, this is the main difference with the single model case where the bottleneck would be single and therefore only one stage could be selected to increase throughput, respectively the first stage for the P1 model or the third stage for P2 or P3 model.

$$\left\{ \begin{array}{l} T'_1(1) = \max \left\{ \frac{20}{2}, \frac{8}{1}, \frac{19}{1} \right\} = 19 \\ T'_2(1) = \max \left\{ \frac{10}{2}, \frac{10}{1}, \frac{25}{1} \right\} = 25 \\ T'_3(1) = \max \left\{ \frac{10}{2}, \frac{11}{1}, \frac{19}{1} \right\} = 19 \\ T'_1(3) = \max \left\{ \frac{20}{1}, \frac{8}{1}, \frac{19}{2} \right\} = 20 \\ T'_2(3) = \max \left\{ \frac{10}{1}, \frac{10}{1}, \frac{25}{2} \right\} = 12.5 \\ T'_3(3) = \max \left\{ \frac{10}{1}, \frac{11}{1}, \frac{19}{2} \right\} = 11 \end{array} \right. \quad (5)$$

**Algorithm 1** Generating a set of configurations for a given balancing

**Require:** the set of workloads  $\{W_k^f\}$  resulting from the balancing

**Ensure:** a set  $S = \{(\{W_k^f\}; \{r_k^1\}), \dots, (\{W_k^f\}; \{r_k^p\})\}$  of  $p$  configurations corresponding to successive incremental capacity throughput increase

- 1:  $r_k \leftarrow 1, \forall k \in 1, \dots, m$
- 2:  $S \leftarrow \{(\{W_k^f\}; \{r_k\})\}$
- 3: **while**  $(\exists k \in 1, \dots, m, f \in F | \frac{W_k^f}{r_k} = T_f \text{ and } r_k < r_{max})$  **do**
- 4:    $k^* = \operatorname{argmin}_{k \in 1, \dots, m} \{D'(k)\}$
- 5:    $r_{k^*} \leftarrow r_{k^*} + 1$
- 6:    $S \leftarrow S \cup (\{W_k^f\}; \{r_k\})$
- 7: **end while**

$$\begin{cases} D'(1) = 60 \times 19 + 30 \times 25 + 10 \times 19 = 2080 \\ D'(3) = 60 \times 20 + 30 \times 12.5 + 10 \times 11 = 1685 \end{cases} \quad (6)$$

We can note that the configuration with the best capacity increment is  $C_c$ . This might seem counter-intuitive that adding a resource on the stage that is bottleneck for the most demanded model (i.e.  $C_b$ ) does not lead to the best capacity increment. In configuration  $C_c$ , the takt time does not change for P1, but the reduction of takt time for model P2 and P3 when adding a resource to stage 3 is high enough to compensate for the difference in the volume of demand. Thus the total time to produce the product mix is lower for  $C_c$  than for  $C_b$ .

$C_c$  is added to the set of configurations that will be returned by the algorithm and it is used for the next iteration.

The set of configurations returned by Algorithm 1 are given by Table 3. As a comparison, Table 4 provides the set of configurations which would be generated by the procedure of Delorme et al. (2016) for the single-model case with P1.

Configuration	$r_1$	$r_2$	$r_3$	$D'$	$\sigma$
$C_a$	1	1	1	2140	1.27
$C_c$	1	1	2	1685	1.55
$C_d$	2	1	2	1085	1.07
$C_i$	2	1	3	1010	1.13
$C_l$	3	1	3	890	1.33
$C_n$	3	2	3	713.33	
<b>Average</b>					<b>1.26</b>

Table 3. Configurations returned by Algorithm 1 for the balancing  $B_1$  in the multi-model case

Configuration	$r_1$	$r_2$	$r_3$	$T_1$	$\sigma$
$C_a$	1	1	1	20	1.05
$C_b$	2	1	1	19	1.90
$C_d$	2	1	2	10	1.05
$C_g$	3	1	2	9.5	1.19
$C_l$	3	1	3	8	1.20
$C_n$	3	2	3	6.67	
<b>Average</b>					<b>1.28</b>

Table 4. Configurations returned by the procedure of Delorme et al. (2016) for the balancing  $B_1$  in the single-model case with P1

The algorithm stops on configuration  $C_n$  because the only stage on which it would be possible to add a resource without exceeding  $r_{max}$  (Stage 2) is not bottleneck for any

of the models, thus adding this resource would not lead to an increase of throughput capacity.

Among all the configurations possibly derived from  $B_1$ , Algorithm 1 only keeps one at each iteration. Figure 3 shows all the configurations that could actually be derived from  $B_1$ , iteratively adding a resource in a bottleneck stage at each iteration. A graph is formed in which an edge  $(C_\alpha, C_\beta)$  specifies that the configuration  $C_\beta$  can be obtained from the configuration  $C_\alpha$  by adding one resource. This graph shows there are significant differences of performance between the configurations with the same number of resources. However, there is only one configuration for each extremal case (with the lowest number of resources and the highest number of resources, respectively), which means that any sequence of configurations will always converge to the configuration  $C_n$ .

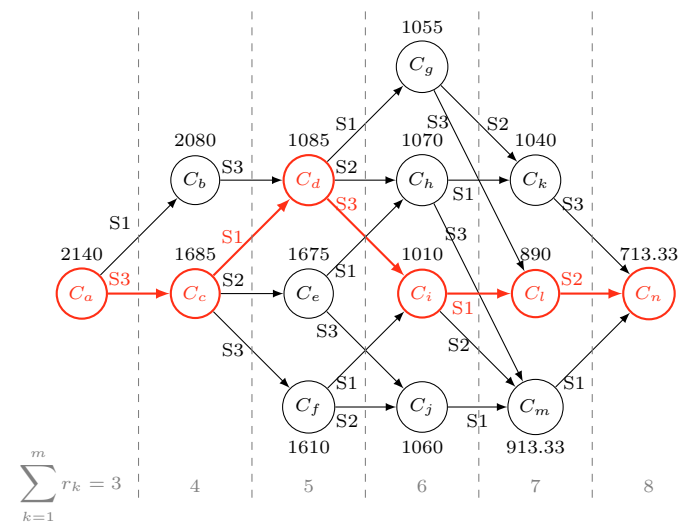

Fig. 3. Graph of all configurations that can be derived from  $B_1$  with an incremental procedure, the weight on the arcs is the station on which the resource have been added and the weight of the vertices is the value of  $D$  for the configuration. The configurations kept by Algorithm 1 are indicated in bold red.

In Figure 4, all configurations are presented in a two dimensional space according to their total number of resources and their  $D$  value, the configurations in red are those kept by Algorithm 1. We can see that on this example, the configurations generated by Algorithm 1 are always the best for each total number of resources added.

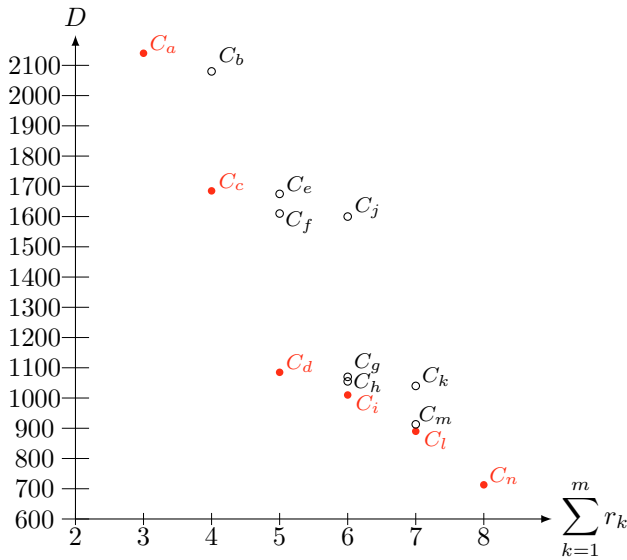

Fig. 4. Number of resources and values of  $D$  of all configurations that can be derived from  $B_1$ , the red circles representing those generated by Algorithm 1 and the white circles corresponding to the other configurations possibly derived by adding resources.

Let us now consider a second balancing  $B_2$  assigning the operations  $\{1, 3, 4\}$  to the first stage,  $\{2, 5, 7\}$  to the second and  $\{6, 8\}$  to the last. The workload on each stage of the RMS is given by Table 5 and the derived configurations in Table 6

	Stage 1	Stage 2	Stage 3	Takt time
Model 1	$W_1^1 = 22$	$W_2^1 = 11$	$W_3^1 = 14$	$T_1 = 22$
Model 2	$W_1^2 = 10$	$W_2^2 = 11$	$W_3^2 = 24$	$T_2 = 24$
Model 3	$W_1^3 = 8$	$W_2^3 = 17$	$W_3^3 = 15$	$T_3 = 17$

Table 5. Workloads and takt times resulting from the balancing  $B_2$  for the three models.

Configuration	$r_1$	$r_2$	$r_3$	$D'$	$\sigma$
$C'_a$	1	1	1	2210	1.28
$C'_b$	2	1	1	1730	1.45
$C'_c$	2	1	2	1190	1.08
$C'_d$	2	2	2	1105	1.25
$C'_e$	3	2	2	885	1.16
$C'_f$	3	2	3	765	1.04
$C'_g$	3	3	3	736.67	
<b>Average</b>					<b>1.21</b>

Table 6. Configurations returned by Algorithm 1 for the balancing  $B_2$

In this second example, the bottleneck stages are different for the three models. Thus adding one resource on a bottleneck stage impacts the productivity of only one model and at minimum three additional resources are needed to impact the three models.

We can also remark that the values of  $D$  are higher for  $B_2$  than for  $B_1$  at same number of resources in total (except one value). This indicates that the productivity of the configurations derived from  $B_2$  is lower than for  $B_1$  which can be explained by the higher initial value of  $D$  (because of a higher takt time on the most demand model) and by the lower average the value of the scalability indicator,

which indicates that on average adding a resource for  $B_1$  gives a higher capacity increment than for  $B_2$ . Thus  $B_1$  is not only more productive than  $B_2$ , it is also more scalable.

### 5. CONCLUSION

Scalability is a very important feature of RMS however its evaluation has not yet been studied in the case of multiple models. In this paper, we suggest to extend an indicator initially presented for single-model RMS. This extension highlights the fact that when dealing with multi-model RMS the choice of the stage where we should add a resource to scale up the throughput capacity is not as straightforward as for single-model RMS.

Indeed, the capacity is increased by adding a resource to a stage which is a bottleneck for at least one the models. The number of new configurations can thus be up to the number of models. In the method we present, we focus on the one leading to the largest capacity increase keeping the same product mix when adding one resource. We illustrate this approach on a didactic example and analyze the quality of the obtained configurations.

Additional experiments are still needed to better analyze the impact of the balancing on the scalability of multi-model RMS but further works could consider the proposed evaluation as a criteria to optimize for the design of RMS. Also, the proposed indicator could be adapted for the case of multi-model lines with setup times or reconfiguration, as well as for the slightly different case of mixed-model lines.

### ACKNOWLEDGEMENTS

This work is supported by the project ANR-21-CE10-0019 “RECONFIDURABLE”.

### REFERENCES

Andersen, A.L., Brunoe, T.D., and Nielsen, K. (2015). Reconfigurable manufacturing on multiple levels: Literature review and research directions. In S. Umeda, M. Nakano, H. Mizuyama, N. Hibino, D. Kiritsis, and G. von Cieminski (eds.), *Advances in Production Management Systems: Innovative Production Management Towards Sustainable Growth*, 266–273. Springer International Publishing, Cham.

Ashraf, M. and Hasan, F. (2018). Configuration selection for a reconfigurable manufacturing flow line involving part production with operation constraints. *International journal of advanced manufacturing technology*, 98(5-8), 2137–2156.

Battaia, O. and Dolgui, A. (2013). A taxonomy of line balancing problems and their solution approaches. *International Journal of Production Economics*, 142(2), 259–277.

Bortolini, M., Galizia, F.G., and Mora, C. (2018). Reconfigurable manufacturing systems: Literature review and research trend. *Journal of Manufacturing Systems*, 49, 93–106.

Cerqueus, A. and Delorme, X. (2021). A bi-objective based measure for the scalability of reconfigurable manufacturing systems. In A. Dolgui, A. Bernard, D. Lemoine, G. von Cieminski, and D. Romero (eds.), *Advances in*

- Production Management Systems. Artificial Intelligence for Sustainable and Resilient Production Systems*, 544–552. Springer International Publishing, Cham.
- Deif, A.M. and ElMaraghy, H.A. (2007). Assessing capacity scalability policies in RMS using system dynamics. *International Journal of Flexible Manufacturing Systems*, 19, 128 – 150.
- Deif, A.M. and ElMaraghy, W.H. (2006). A control approach to explore the dynamics of capacity scalability in reconfigurable manufacturing systems. *Journal of Manufacturing System*, 25(1), 12 – 24.
- Delorme, X., Malyutin, S., and Dolgui, A. (2016). A multi-objective approach for design of reconfigurable transfer lines. *IFAC-PapersOnLine*, 49(12), 509–514.
- Dolgui, A., Hashemi-Petroodi, S.E., Kovalev, S., and Kovalyov, M.Y. (2021). Profitability of a multi-model manufacturing line versus multiple dedicated lines. *International Journal of Production Economics*, 236, 108113.
- Dou, J., Dai, X., and Meng, Z. (2010). Optimisation for multi-part flow-line configuration of reconfigurable manufacturing system using GA. *International Journal of Production Research*, 48(14), 4071–4100.
- Freiheit, T., Shpitalni, M., and Hu, S.J. (2004). Productivity of paced parallel-serial manufacturing lines with and without crossover. *Journal of Manufacturing Science and Engineering*, 126, 361–367.
- Hees, A., Schutte, C.S., and Reinhart, G. (2017). A production planning system to continuously integrate the characteristics of reconfigurable manufacturing systems. *Production Engineering*, 11(4-5), 511–521.
- Hu, S., Ko, J., Weyand, L., ElMaraghy, H.A., Lien, T.K., Koren, Y., Bley, H., Chrystolouris, G., Nasr, N., and Shpitalni, M. (2011). Assembly system design and operations for product variety. *CIRP Annals*, 60(2), 715–733.
- Hu, Y., Guan, Y., Han, J., and Wen, J. (2017). Joint optimization of production planning and capacity adjustment for assembly system. *Procedia CIRP*, 62, 193 – 198.
- Kabir, M. and Tabucanon, M.T. (1995). Batch-model assembly line balancing: A multiattribute decision making approach. *International Journal of Production Economics*, 41, 193–201.
- Koren, Y., Gu, X., and Guo, W. (2018). Reconfigurable manufacturing systems: Principles, design, and future trends. *Frontiers of Mechanical Engineering*, 13(2), 121 – 136.
- Koren, Y., Hu, S.J., and Weber, T.W. (1998). Impact of manufacturing system configuration on performance. *Annals of the CIRP*, 47(1), 369 – 372.
- Koren, Y. and Shpitalni, M. (2010). Design of reconfigurable manufacturing systems. *Journal of Manufacturing Systems*, 29, 130–141.
- Koren, Y., Wang, W., and Gu, X. (2017). Value creation through design for scalability of reconfigurable manufacturing systems. *International Journal of Production Research*, 55(5), 1227 – 1242.
- Kovalev, S., Delorme, X., Dolgui, A., and Oulamara, A. (2017). Minimizing the number of stations and station activation costs for a production line. *Computers and Operations Research*, 79, 131–139.
- Moghaddam, S.K., Houshmand, M., Saitou, K., and Fatahi Valilai, O. (2020). Configuration design of scalable reconfigurable manufacturing systems for part family. *International Journal of Production Research*, 58(10), 2974–2996.
- Napoleone, A., Andersen, A., Pozzetti, A., and Macchi, M. (2019). Reconfigurable manufacturing: A classification of elements enabling convertibility and scalability. In F. Ameri, K. Stecke, G. von Cieminski, and D. Kiritsis (eds.), *Advances in Production Management Systems. Production Management for the Factory of the Future. APMS 2019*, volume 566 of *IFIP Advances in Information and Communication Technology*, 349–356. Springer, Cham.
- Rösiö, C., Aslam, T., Srikanth, K.B., and Shetty, S. (2019). Towards an assessment criterion of reconfigurable manufacturing systems within the automotive industry. *Procedia Manufacturing*, 28, 76–82.
- Sivasankaran, P. and Shahabudeen, P. (2014). Literature review of assembly line balancing problems. *The International Journal of Advanced Manufacturing Technology*, 73, 1665–1694.
- Son, S.Y., Olsen, T.L., and Yip-Hoi, D. (2001). An approach to scalability and line balancing for reconfigurable manufacturing systems. *Integrated Manufacturing Systems*, 12(7), 500 – 511.
- Thomopoulos, N.T. (1970). Mixed Model Line Balancing with Smoothed Station Assignments. *Management Science*, 16(9), 593–603.
- van Zante-de Fokkert, J.I. and de Kok, T.G. (1997). The mixed and multi model line balancing problem: a comparison. *European Journal of Operational Research*, 100(3), 399–412.
- Wang, G.X., Huang, S.H., Yan, Y., and Du, J.J. (2017). Reconfiguration schemes evaluation based on preference ranking of key characteristics of reconfigurable manufacturing systems. *International Journal of Advanced Manufacturing Technology*, 89, 2231–2249.
- Wang, W. and Koren, Y. (2012). Scalability planning for reconfigurable manufacturing systems. *Journal of Manufacturing Systems*, 31(2), 83 – 91.
- Yelles-Chaouche, A.R., Gurevsky, E., Brahimi, N., and Dolgui, A. (2020). Minimizing task reassignments in the design of reconfigurable manufacturing lines with space restrictions. In *21st IFAC World Congress*. Berlin, Germany.
- Yelles-Chaouche, A.R., Gurevsky, E., Brahimi, N., and Dolgui, A. (2021). Reconfigurable manufacturing systems from an optimisation perspective: a focused review of literature. *International Journal of Production Research*, 59(21), 6400–6418.
- Youssef, A.M.A. and ElMaraghy, H.A. (2008). Availability consideration in the optimal selection of multiple-aspect RMS configurations. *International Journal of Production Research*, 46(21), 5849–5882.